

**R16**

Code No: 131AE

JAWAHARLAL NEHRU TECHNOLOGICAL UNIVERSITY HYDERABAD

B. Tech I Year I Semester Examinations, January/February - 2024

ENGINEERING MECHANICS

(Common to CE, EEE, ME, ECE, CSE, EIE, IT, MCT, AE, MIE)

Time: 3 Hours

Max. Marks: 75

Note: i) Question paper consists of Part A, Part B.

ii) Part A is compulsory, which carries 25 marks. In Part A, answer all questions.

iii) In Part B, Answer any one question from each unit. Each question carries 10 marks and may have a, b as sub questions.

**PART - A**

**(25 Marks)**

- 1.a) Distinguish between the Coplanar and Non-coplanar force. [2]
- b) What is the difference between moment and a couple? [3]
- c) Define the term screw Jack. [2]
- d) Define limiting friction and angle of repose. [3]
- e) State the theorem of pappus. [2]
- f) Define principal axes and principal moment of inertia. [3]
- g) Differentiate between polar moment of inertia and product of inertia. [2]
- h) Define mass moment of inertia. [3]
- i) State the work-energy equation for translation. [2]
- j) What is principle of conservation of energy? [3]

**PART - B**

**(50 Marks)**

- 2.a) The following forces act at a point:
  - i) 30N inclined at  $32^\circ$  towards North of East.
  - ii) 15N towards North
  - iii) 20N towards North West and
  - iv) 45N inclined at  $45^\circ$  towards South of west. Find the magnitude and direction of the resultant force.
- b) Two cylinders are kept in a channel as shown in figure 1. Determine the reactions at all the contact points A, B, C and D. Assume the contact Surfaces are smooth. [5+5]

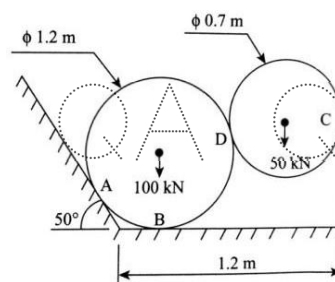

Figure 1

QA QA QA QA QA QA QA QA QA

OR

3.a) Explain the Converse of the law of Triangle of forces and converse of the law of polygon of forces.

b) Show that if three coplanar forces, acting at a point be in equilibrium, then, each force is proportional to the sine of the angle between the other two. [5+5]

4.a) How will you distinguish between static friction and dynamic friction? State the laws of friction?

b) A body, resting on a rough horizontal plane, required a pull of 190 N inclined at  $30^\circ$  to the plane just to move it. It was found that a push of 240 N inclined at  $30^\circ$  to the plane just moved the body. Determine the weight of the body and the coefficient of friction. [5+5]

OR

5.a) A body of weight 500 N lying on a rough plane inclined at an angle of  $25^\circ$  with horizontal. It is supported by an effort (P) parallel to the plane as shown in figure 2. Determine the minimum and maximum, value of P, for which the equilibrium can exist, If the angle of friction is  $20^\circ$ .

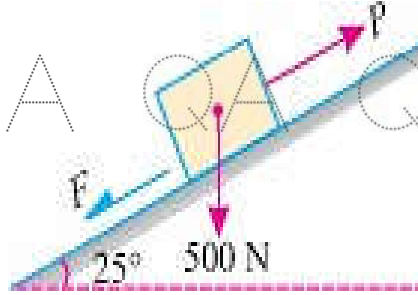

Figure 2

b) Obtain the relation for moment due to effort and load to be raised is a screw jack. [5+5]

6.a) Find the centroid of the plane lamina as shown in the figure 3.

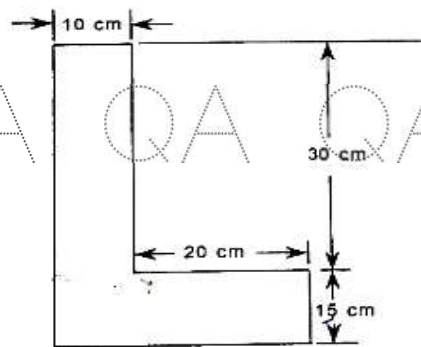

Figure 3

b) Define moment of Inertia of an area about an axis. Name the most important use of radius of gyration. [5+5]

OR

QA QA QA QA QA QA QA QA QA

QA QA QA QA QA QA QA QA QA

7.a) Find the Centre of gravity of the I-section as shown in figure 4.

QA QA QA QA QA QA QA QA QA

QA QA QA QA QA QA QA QA QA

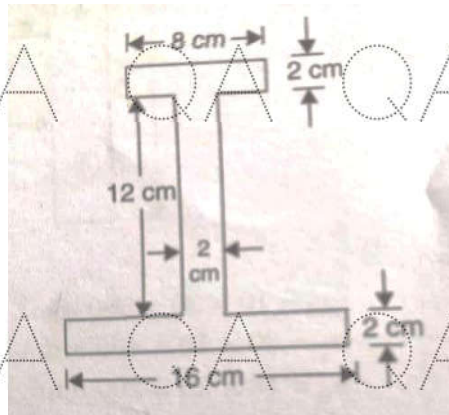

Figure 4

b) State and prove perpendicular axis theorem. [5+5]

8.a) Differentiate between mass moment of inertia and area moment of inertia in detail.

b) Obtain an expression for mass moment of inertia for a hollow cylinder of mass 'm', external radius 'R' and internal radius 'r'. [5+5]

OR

9.a) Determine the mass moment of inertia of a solid cylinder about centroidal axes.

b) Obtain an expression for the mass moment of inertia of a homogeneous sphere of radius 'r' with respect to any diameter. [5+5]

10. Two bodies A and B of mass 80 kg and 20 kg are connected by a thread and move along a horizontal plane under the action of force 400 N applied to the first body of mass 80kg. The coefficient of friction between the sliding surfaces of the bodies and the plane is 0.3. Determine the acceleration of the two bodies and the tension in the thread using D' Alembert's principle. [10]

OR

11.a) State law of conservation of energy. Explain clearly the term 'recoil of gun'. How will you find the velocity of the bullet?

b) Two masses of 40 kg and 35 kg respectively are attached by a cord that passes over a frictionless pulley. If the masses start from the rest, find the distance covered by either mass in 6 seconds. [5+5]

---ooOoo---

QA QA QA QA QA QA QA QA QA

QA QA QA QA QA QA QA QA QA